

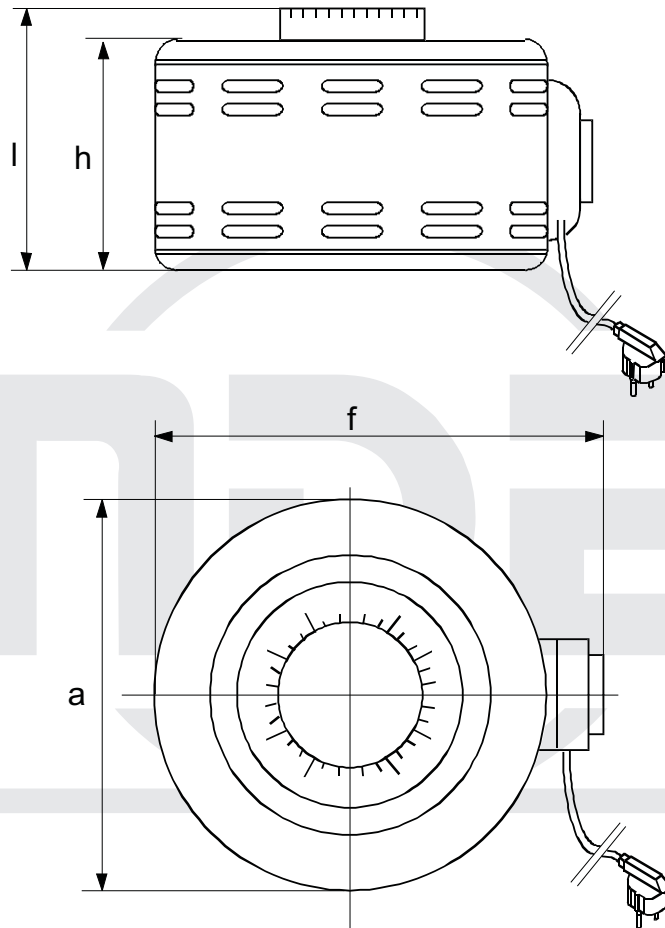

KARTA KATALOGOWA

KK WSM/HSN - 03/09

Rozwiązanie mechaniczne autotransformatora regulowanego w obudowie
 Catalogue card KK WSM/HSN.... - 03/09 Mechanical solution autotransformer with regulation in casing
 Katalogseite KK WSM/HSN.... - 03/09 Mechanische Auflösung der Autotransformators
 Каталоговая карта KK WSM/HSN.... - 03/09 Механические решения трансформации



Karta katalogowa Catalogue card Katalogseite Каталоговая карта	Moc Power Leistung Мощность	Wymiary Dimensions Ausmaße Размеры											Typ końcówki Type of pin Anschlussart Тип штыфтва	Masa Weight Masse Масса	
		a	--	f	--	h	--	l	--	--	--	--			
		mm													kg
KK WSM/HSN 0103-03/09	1250	170	--	206	--	136	--	157	--	--	--	--	--	PS,X	6,0
KK WSM/HSN 0203-03/09	1820	202	--	240	--	136	--	157	--	--	--	--	--	PS,X	8,5
KK WSM/HSN 0303-03/09	3380	268	--	305	--	134	--	157	--	--	--	--	--	PS,X	12,0