



# KARTA KATALOGOWA

# KK WSP/Z8-16/16

Rozwiązanie mechaniczne UMS - układu miękkiego startu

Catalogue card KK WSP/Z8-16/16 of UMS - soft start

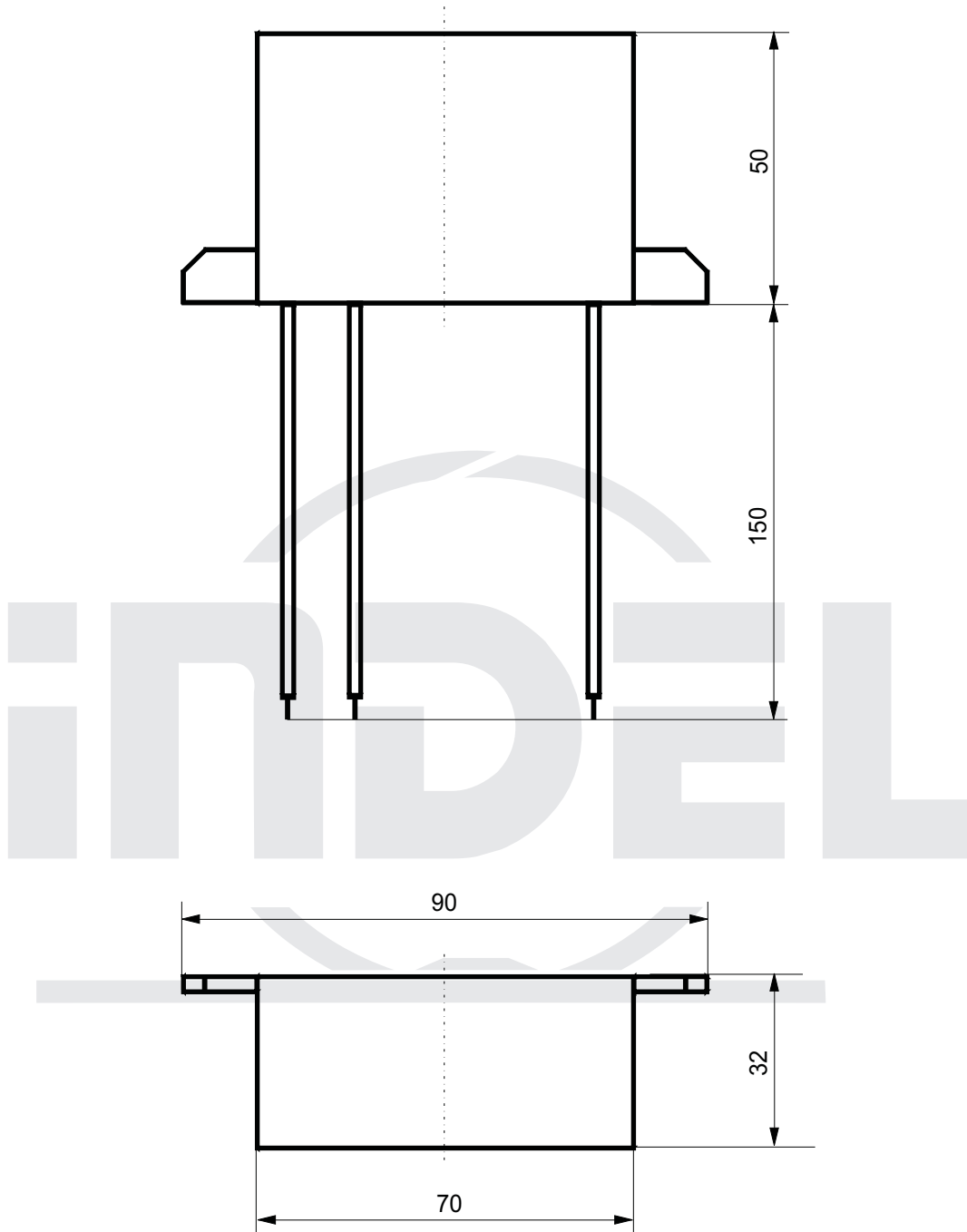

Typ Type	Moc Power	Masa Weight	Typ końcówki Type of pin	Uwagi: Comments:
UMS 0-2,5kVA	0-2,5kVA	0,10 kg	P	
UMS 0-6kVA	0-6kVA	0,13 kg	P	